

**The Sweater Wizard: /Weight: medium /Ease: standard /Length: top hip**

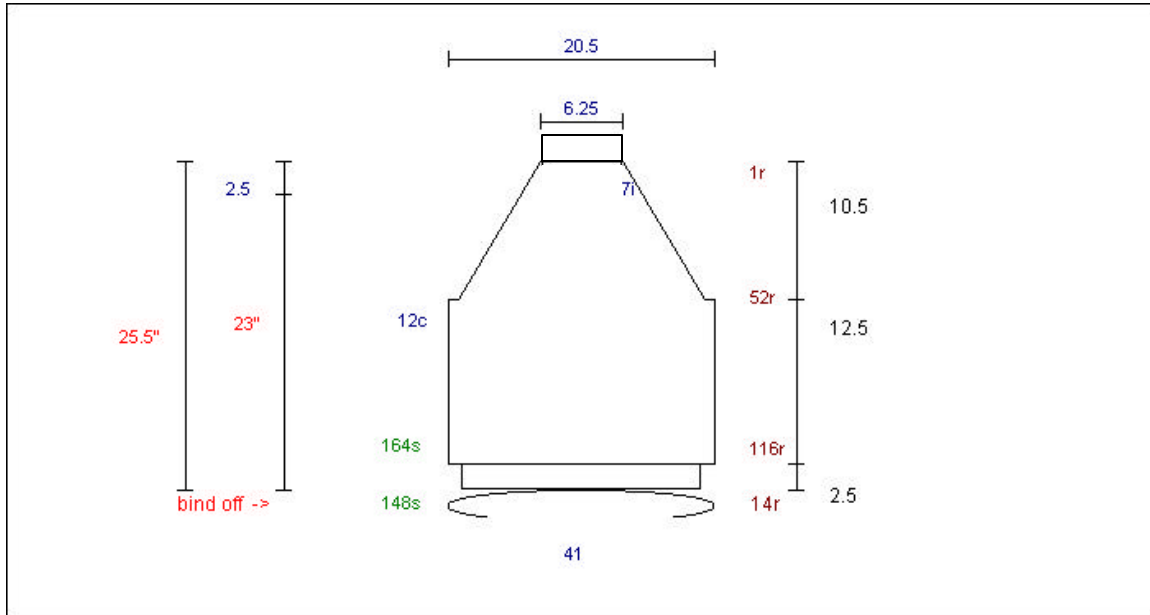

Needles: # , # Size: 36

Gauge: 4.00 sts = 1" 5.00 rws = 1"

Estimated Ydg: 820

With larger needle, cast on ~~48~~ 72 sts. Set Up Row

RS: Knit 26, place marker, K1 (seam st), place marker, work 8 sts (sleeve sts), place marker, work 1 st (seam st), place marker, work 26 sts (back sts), place marker, work 1 st (seam st), place marker, work 8 sts (sleeve sts), place marker, work 1 st (seam st), place marker for beginning of round.

26 front neck, 1 seam, 8 sleeve, 1 seam, 26 back neck, 1 seam, 8 sleeve, 1 seam

**Funnel Neck**

Working in rounds work 2" even in desired pattern stitch.

**Begin Bodice Shaping:** Working in the round, inc 8 sts on every other round as follows:

\*Work to the marker, M1, slip marker, k1 (seam st), slip marker, M1; Repeat from \*.

Continuing increasing until stitch count is as follows:

Sts: [50, 68, 50, 68, + 4 seam sts.]

Work even until 52 rounds [10.5"] have been completed.

Using a tapestry needle, slip all the sts from from each section onto separate pieces of scrap yarn. Sequence:

sleeve sts, back sts + 2 seam sts, sleeve sts, front sts + 2 seam sts.

Sts: 50, 70, 50, 70

Work Sleeves

continued on page 2

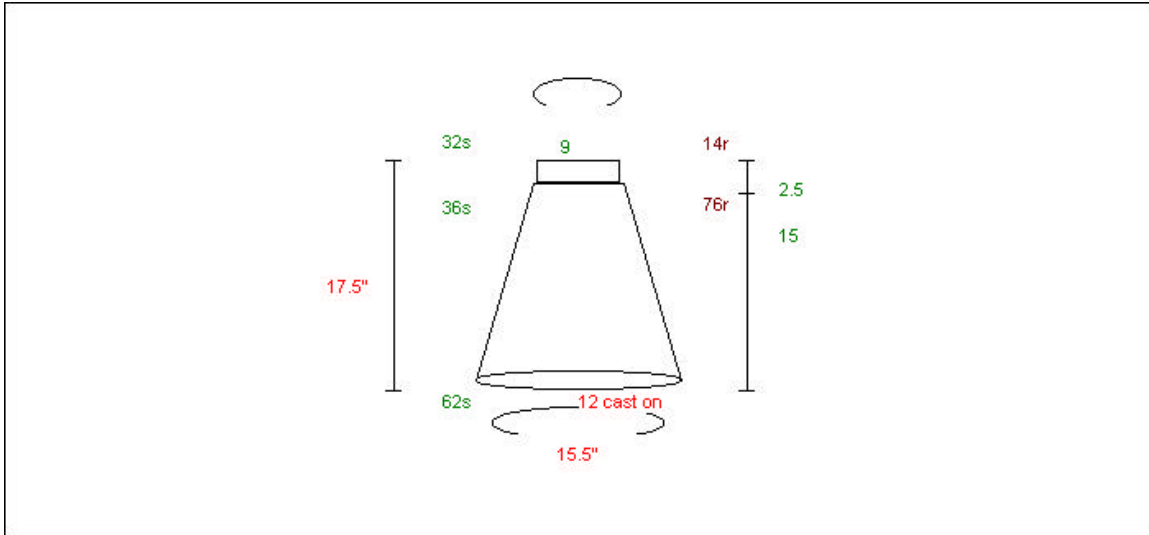

Sleeves (make 2)

With larger size circular needle cast on 6 sts, slip 50 sleeve sts from scrap yarn and work, cast on 6 sts, place marker and join.

Sleeve Decreases

Establish pattern.

Dec 1 st on each side of marker every 5 rounds 6x then every 6 rounds 7x.

Continue in pat st until piece meas 15"[row 76].

Change to smaller needles for ribbing.

Rib-Multiple Options

2 4 8 16

Sleeve-to-Rib Dec Row

[Work 6 k2tog, work 5, k2tog] 2x work 6.

Work rib for 14 rounds[2.5"].

Bind off 32 sts.

Work Body

Slip front and back body sts onto a circular needle. Cast on 6 sts, work across front, cast on 6 sts, place marker(side seam), cast on 6 sts, join front and back, work across back, cast on 6 sts, place marker(beginning of round marker), Join. One round complete.

Work in rounds until underarm to

bottom measures 12.5 "

Body-to-Rib Dec Round

Work 8

[K2tog, work 7, K2tog, work 8]2x

[K2tog, work 7] 4x

to first marker. Repeat sequence to end.

Change to smaller needles and work in desired rib for 2.5". Bind off.

Graft underarms.

Standard Neck Finishing

Note: Term "neck edge" includes stitches set aside for sleeve in set-up row.

With smaller size 16" circular needle or dpn set , pick up 80 sts around neck edge. Inc or dec as necessary

on the first row to balance pattern.

Work in desired ribbing for 1" or desired length. Bind off loosely.